



Equipment for the Foodservice Industry

value + quality + service

## Nugget Ice Machine

Model No:

# IM-550-NUGGET



### IM-550-NUGGET

### Features

Features:

- Corrosion resistant
- Gliding door allows easy access to ice in the bin
- Simple and intuitive control panel
- A smaller nugget sized ice is softer and more chewable than standard cubes
- Ice scoop included
- Adjustable leveling legs

Warranty:

- One year parts and labour. For full warranty details visit <https://www.efifoodequip.com/warranty-info.php>



**IM-550-NUGGET**

**Specifications**

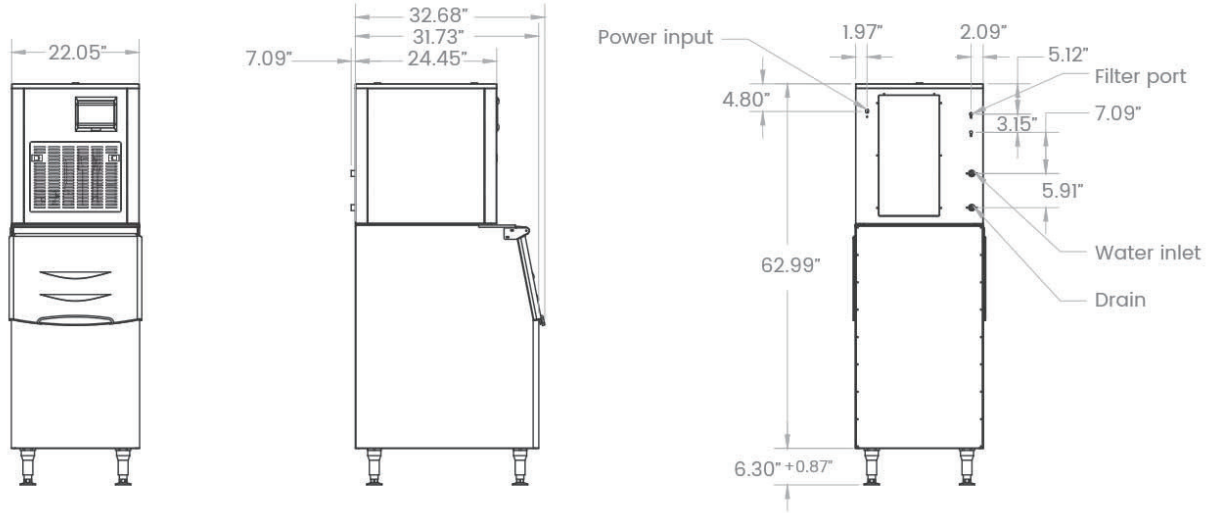

Model	Refrigerant	Dimension (mm) (inch)			Condenser Unit	Voltage (V/Hz)	Power (W)	Bin Capacity (kg) (lb)	Output LB/24hr (kg) (lb)	Net Weight (kg) (lb)
		W	D	H						
IM-550-NUGGET	R290	560	830	1760	Air	110/60	1180	125	250	71
		22	32.7	69.3				275	550	157

Specifications subject to change without notice.