



Equipment for the Foodservice Industry  
value + quality + service

## X-LINE 27" Worktop Freezer with Backsplash

Model No:  
**FWDR1-27VCX-L**



### FWDR1-27VCX-L Features

#### Features:

- Exterior & interior stainless steel construction
- Environmentally friendly R290 refrigerant
- Heavy duty Embraco compressor
- Self-closing and stay open door
- Efficient refrigeration system holds -8°F to 1°F (-22°C to -18°C)
- Recessed door handle
- Removable gasket that is easy to clean and replace
- Casters for easy movement
- Pre-installed shelves

#### Warranty:

- Two year parts and labour; Five years on compressor. *For full warranty details visit <https://www.efifoodequip.com/warranty-info.php>*



**FWDR1-27VCX-L Specifications**

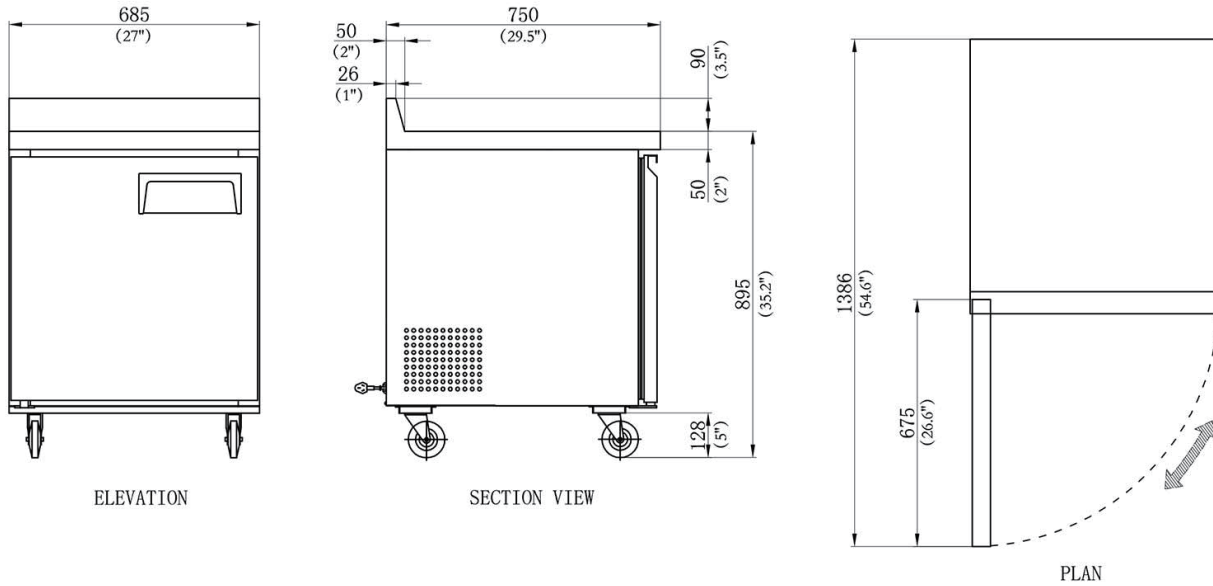

Model	Refrigerant	Doors	Shelves	Dimension (mm) (inch)			HP	Voltage	Amps	Capacity (L) (Cu Ft.)	Net Weight (KG) (LBS)	Temperature Range
				W	D	H						
FWDR1-27VCX-L	R290	1	1	685	750	984	1/5	115/60	1.8	202	72	-8 ~ -1°F
				27	29.5	38.7				7.2	158.7	-22 ~ -18°C

Equipped with one NEMA 5-15P plug 

**Shipping Information**

Crate Dimensions (mm) (inch)			Net Weight (KG) (LBS)	Gross Weight (KG) (LBS)
W	D	H		
755	820	1070	72	92
29.7	32.3	42.1	158.7	202.8

Specifications subject to change without notice.