



Equipment for the Foodservice Industry

value + quality + service

## X-LINE 27" Worktop Refrigeration with Backsplash

Model No:

**CWDR1-27VCX-R**



### CWDR1-27VCX-R Features

Features:

- Exterior & interior stainless steel construction
- Environmentally friendly R290 refrigerant
- Heavy duty Embraco compressor
- Self-closing and stay open door
- Efficient refrigeration system holds 33°F to 45°F (0.5°C to 8°C)
- Recessed door handle
- Removable gasket that is easy to clean and replace
- Casters for easy movement
- Pre-installed shelves

Warranty:

- Two year parts and labour; Five years on compressor. *For full warranty details visit <https://www.efifoodequip.com/warranty-info.php>*



**CWDR1-27VCX-R Specifications**

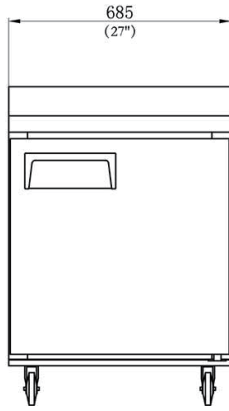

ELEVATION

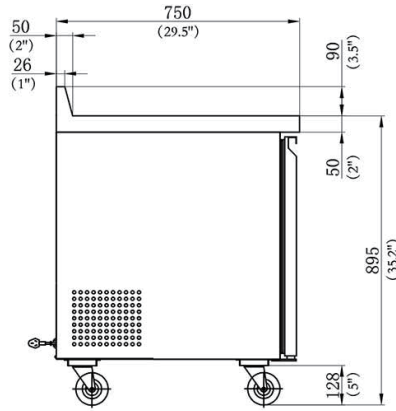

SECTION VIEW

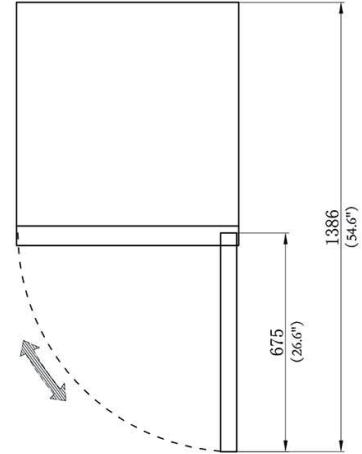

PLAN

Model	Refrigerant	Doors	Shelves	Dimension (mm) (inch)			HP	Voltage	Amps	Capacity (L) (Cu Ft.)	Net Weight (KG) (LBS)	Temperature Range
				W	D	H						
CWDR1-27VCX-R	R290	1	1	685	750	984	1/6	115/60	2.3	202	72	0.5 ~ 8°C
				27	29.5	38.7				7.2	158.7	33 ~ 45°F

Equipped with one NEMA 5-15P plug 

**Shipping Information**

Crate Dimensions (mm) (inch)			Net Weight (KG) (LBS)	Gross Weight (KG) (LBS)
W	D	H		
755	820	1070	72	92
29.7	32.3	42.1	158.7	202.8

Specifications subject to change without notice.