



Equipment for the Foodservice Industry
value + quality + service

X-LINE 72" Undercounter Solid Door Refrigerator

Model No:
CUDR3-72VCX



CUDR3-72VCX

Features

Features:

- Stainless steel interior and exterior, aluminum back
- Rounded corner design inside the cabinet for easy cleaning
- Self-closing swing door w/90° stay open feature
- Heavy duty recessed pull handles
- Adjustable/removable plastic coated wire shelves
- R290 refrigeration system holds 33°F to 41°F (0.5°C to 5°C)
- Electronic control system makes it easy to adjust temperature set point and defrost frequency

- Casters with brakes for easy movement
- Easy to access condenser coil for cleaning and service

Warranty:

- Two year parts and labour; Five years on compressor. For full warranty details visit <https://www.efifoodequip.com/warranty-info.php>



CUDR3-72VCX Specifications

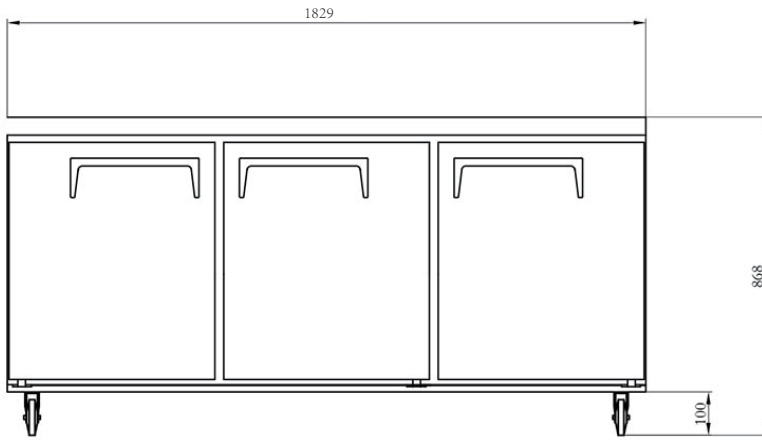

ELEVATION

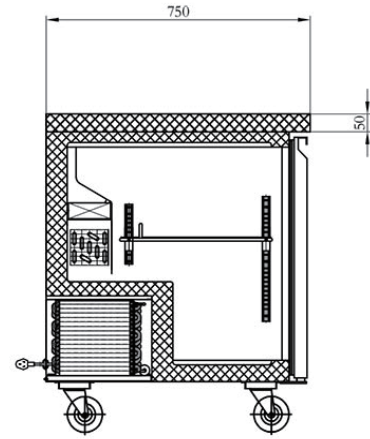

SECTION VIEW

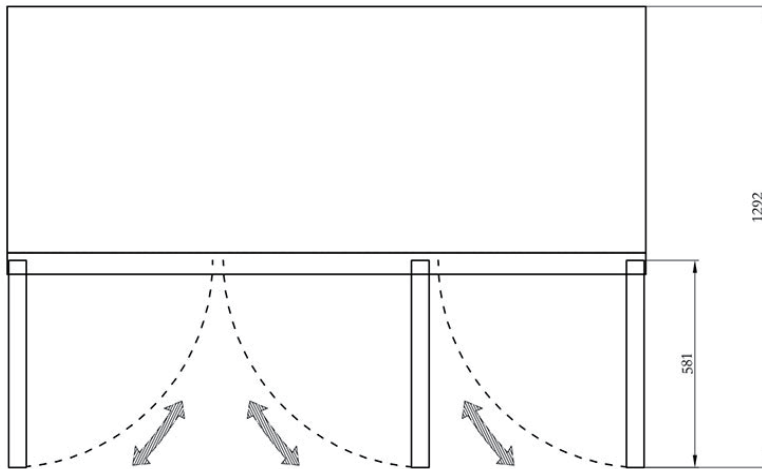

PLAN

Model	Refrigerant	Doors	Shelves	Dimension (mm) (inch)			HP	Voltage	Amps	Capacity (L) (Cu Ft.)	Net Weight (KG) (LBS)	Temperature Range
				W	D	H						
CUDR3-72VCX	R290	3	3	1829	750	868	1/4	115/60	3.12	440	298	33 ~ 41°F
				72	29.5	34.1				15.5	198	0.5 ~ -5°C

Specifications subject to change without notice.